

Drum ventilation unit

Basic ventilation unit for drum dryer installations.

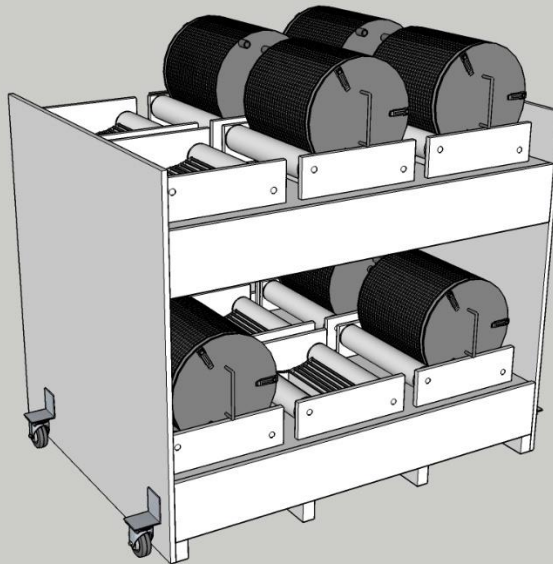

Standard 2x 6 drums, other capacities on demand.
Per level a roll drive with motor. The unit is easy to transport by rolls or by forklift

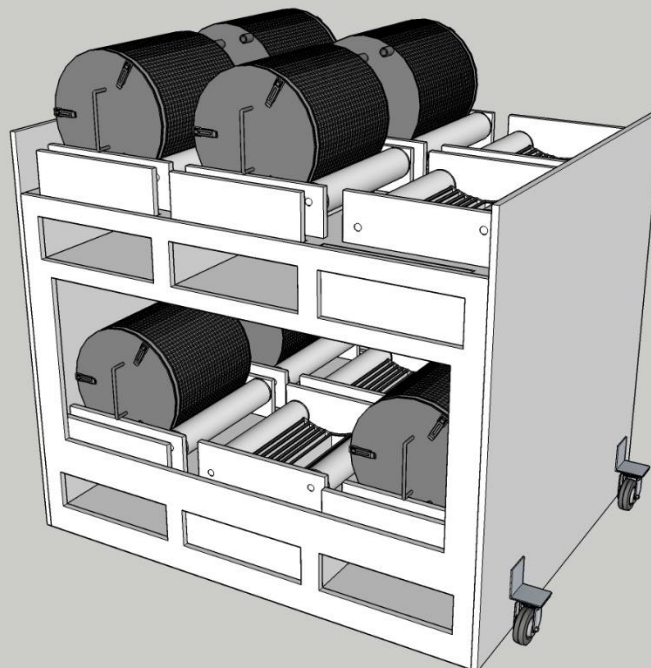

2x 3 inlets for 2 drums each. Each inlet has a slide for closing.

Drum ventilation unit

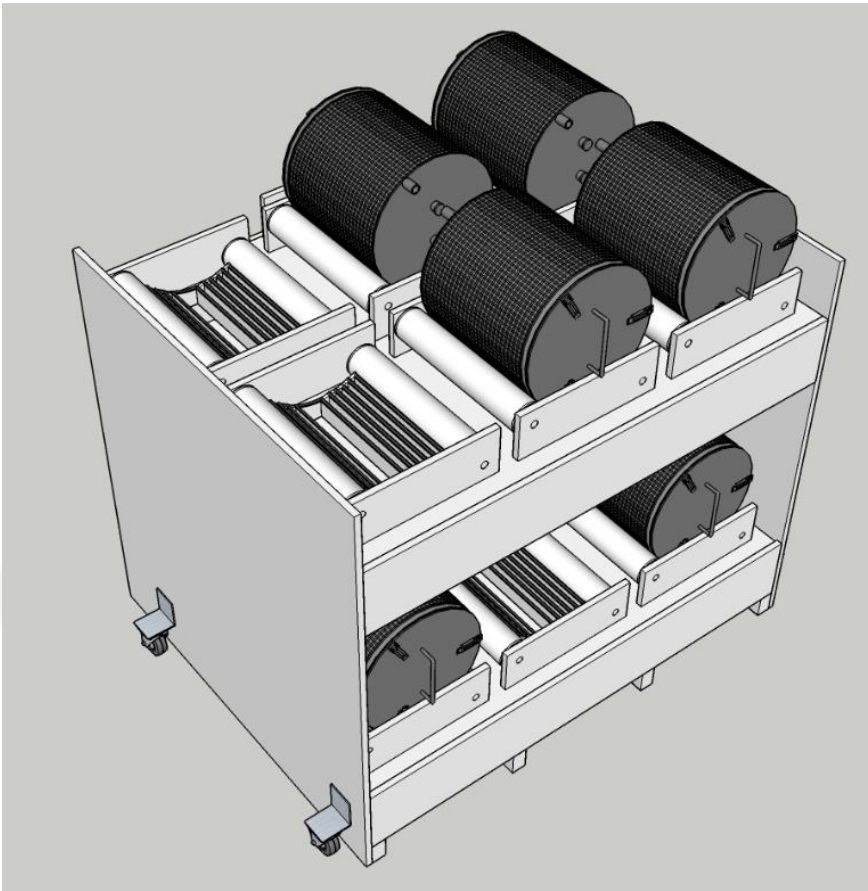

Motor driven roll per single, double or triple drums possible.

Per motor driven roll a variable speed is possible.

Ventilation unit tailor-made to fit for every type of drum.

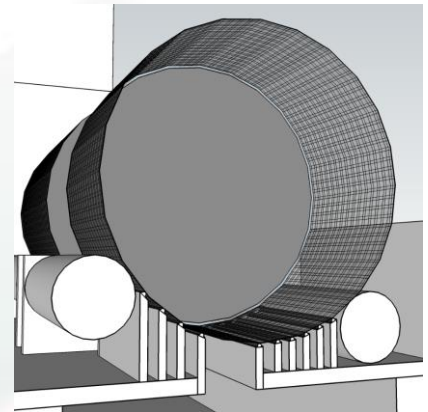

Special exhaust outlet to prevent air escaping along the seed instead of through it.

Ventilation units for different drum dryer installations

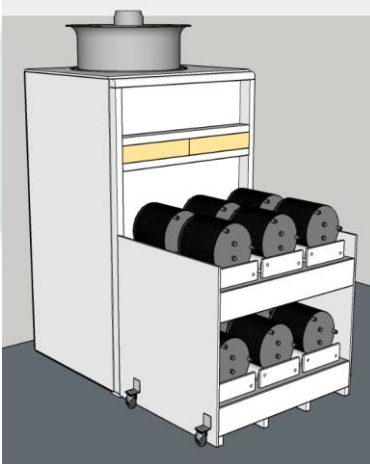

Box drying installation

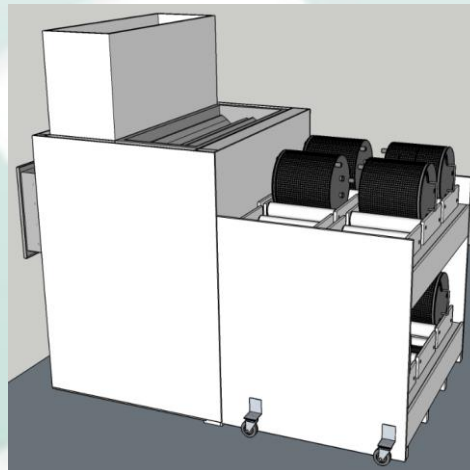

Open drum dryer

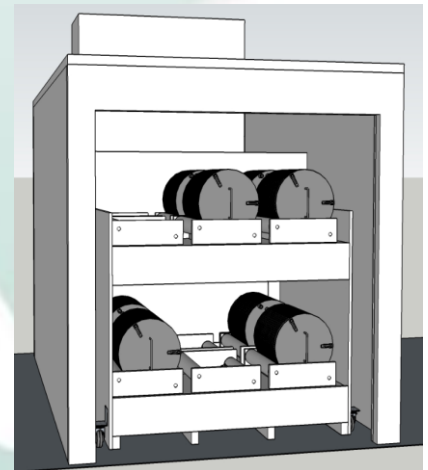

Closed drum dryer

See our prospect for more information about these drum dryers